

# PNEUMATIC ACTUATOR

Scotch-yoke Power Actuator

Scotch-yoke mechanism which produces a torque curve that closely match with the torque requirements of rotating valves



AKCESERVIS

## 大力矩 气动执行器 High Quality Actuator

- 埃克赛维斯(AKCESERVIS)气动执行器采用的是拨叉式结构.相比同一缸径尺寸的齿轮齿条结构执行器,输出的扭矩更大.
- 除此之外,拨叉式结构动作传递给执行器输出轴产生的扭矩曲线,更匹配角行程旋转类阀门的力矩曲线,如球阀、蝶阀。

### AKCESERVIS执行器还具有以下优点:

- 优化的设计使开/关行程可调角度达到 $90^{\circ} \pm 10^{\circ}$ 。另外,可以做到在 $100^{\circ}$ 旋转范围内,锁定任意角度。这非常适用于要求带机械限位来限制阀门开度的用户和非 $90^{\circ}$ 旋转的设备。
- 输出轴的上、下两个金属自润滑轴承嵌入在缸体上,这种钢性支撑设计区别于其它执行器的工程塑料材质承载结构,最大限度的保护了输出轴,使其一直处在垂直的状态,不会受外力的影响发生倾斜,造成密封圈偏磨而减低使用寿命.
- 实验测试: 超过1,300,000次无泄露

AKCESERVIS pneumatic actuator utilize scotch yoke type ,which is able to produce much more torque than that of rack-and-pinion actuator of the same cylinder bore.

In addition, the torque curve that transferred to actuator output shaft from scotch yoke type betterly match with the torque curve of rotary type valves, such as ball valves and butterfly valves.

### AKCESERVIS actuator also have the following advantages:

- Rotary angle range up to  $90^{\circ} \pm 10^{\circ}$  . In addition, it is able to fix at any angle within  $100^{\circ}$  rotating range, which is very suitable for the devices that rotate in non- $90^{\circ}$ .
- Distinguishing from the engineering plastic bearing of other actuators, two top and bottom metallic bearings of output shaft are embedded on body. This type of rigid-support design achieves 30% more life cycle.
- Experimental test: no leakage over 1300000 times tests

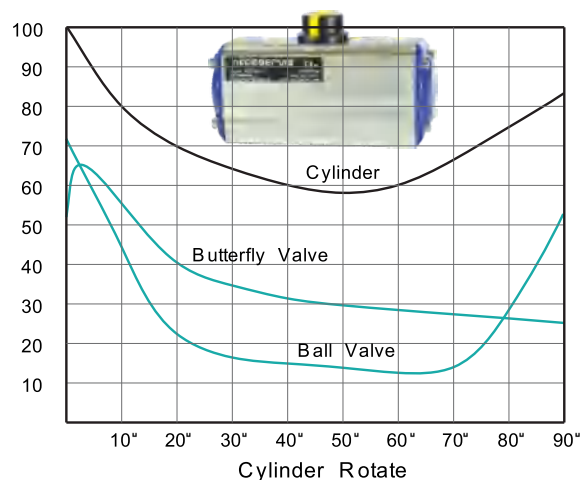

# 适合海洋大气 高温、高湿、高盐雾 环境的产品

The products that are suitable for the marine environment (high-temperature, high-humidity, high salt spray)



埃克赛维斯(AKCESERVIS)微等离子体氧化技术处理的产品表面是陶瓷化的氧化膜。与喷涂在产品表面得到的陶瓷膜不同，这是金属基体原位生长的陶瓷膜，因此致密均匀，结合牢固。耐腐蚀性能、耐磨硬度、绝缘性能非常突出。

中性盐雾性能：800-1000h，最高2000h。

硬度：1000-2000HV，最高可达3000HV，与硬质合金相同。

绝缘性能：电阻值100MΩ，有效防止电化学腐蚀。

AKCESERVIS utilize Aluminium micro-arc oxidation on metal. Because they can represent high hardness and a continuous barrier, these coatings can offer protection against wear, corrosion or heat as well as electrical insulation.

The coating is a chemical conversion of the substrate metal into its oxide, and grows both inwards and outwards from the original metal surface. Because it grows inward into the substrate, it has excellent adhesion to the substrate metal.

Neutral salt spray performance: 800-1000h. Maximum :2000h.

Hardness: 1000-2000HV, Maximum 3000HV, which is the same as that of hard alloy.

Electrical insulation performance : resistance value: 100MΩ, sufficiently prevent galvanic corrosion



## 陶瓷氧化膜显微形貌

显微放大看到的原位生长、熔融状态的陶瓷膜结构,晶粒细小致密. 这是硬质阳极氧化工艺无法达到的。

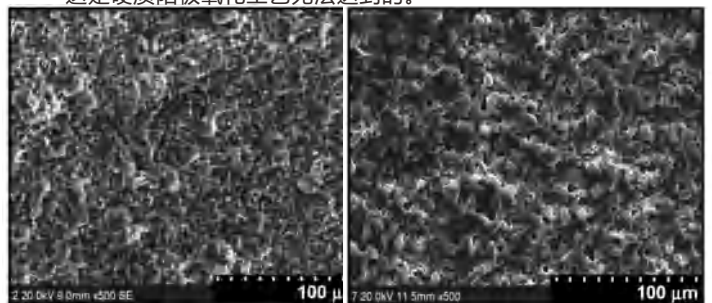

Micro structure of micro-arc oxidation ceramic surface

# PNEUMATIC ACTUATOR Scotch Yoke Type

## 零件图 PART LIST

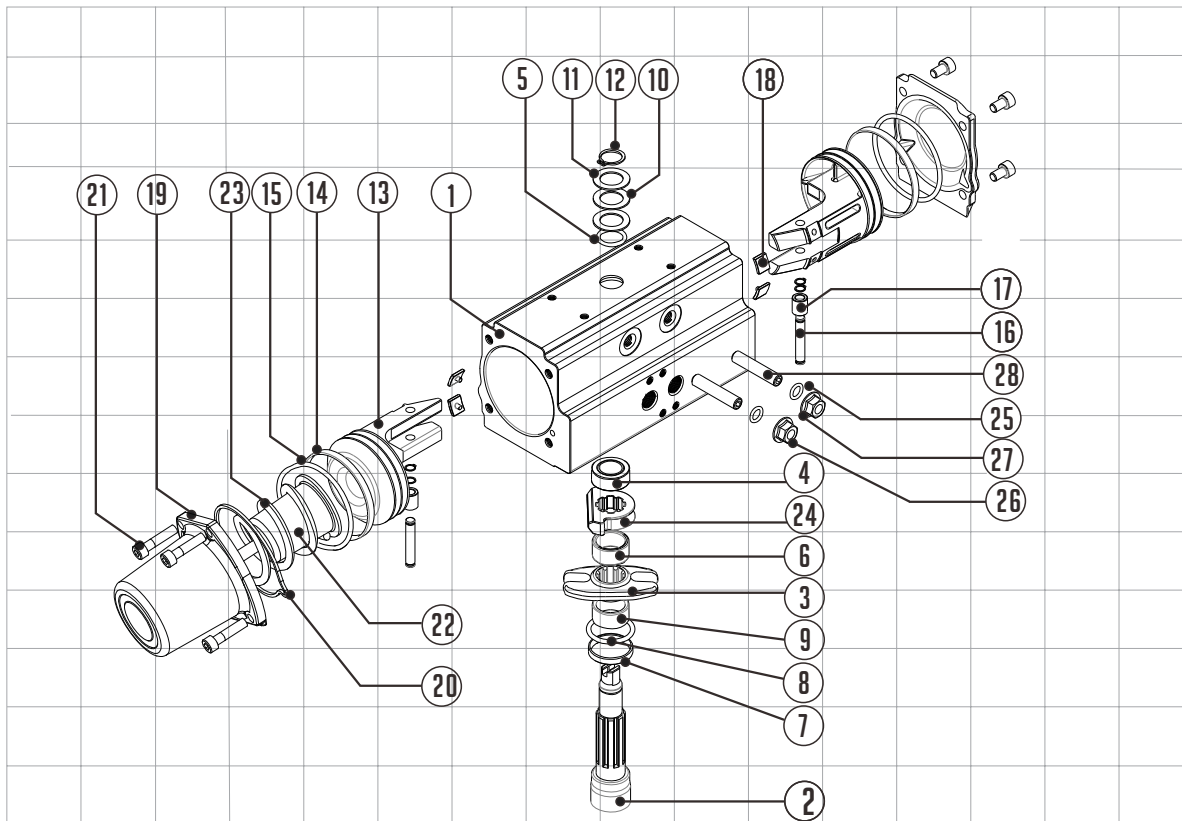

NO	零件名称 PART NAME	材质 MATERIALS	备注 REMARKS
1	缸体 BODY	挤压铝合金 EXTRUDED ALUMINUM	硬质阳极氧化 HARD ANODIZED
2	轴 SHAFT	合金钢 STEEL ALLOY	镀镍 NICKL PLATED
3	拨叉 CRANK	合金钢 STEEL ALLOY	
4	缸体上轴承 BODY TOP BEARING	合金钢+PTFE STEEL ALLOY+PTFE	
5	缸体上密封圈 BODY TOP O-RING	NBR / EPDM / FKM	标配 STANDARD:NBR
6	轴上部导向套 TOP SHAFT ROLLER	工程塑料 ENGINEERING PLASTIC	
7	缸体下轴承 BODY BOTTOM BEARING	合金钢+PTFE STEEL ALLOY+PTFE	
8	缸体下密封圈 BODY BOTTOM O-RING	NBR / EPDM / FKM	标配 STANDARD:NBR
9	轴下部导向套 BOTTOM SHAFT ROLLR	工程塑料 ENGINEERING PLASTIC	
10	下垫圈 BODY BOTTOM WASHER	合金钢 STEEL ALLOY	
11	上垫圈 BODY TOP WASHER	合金钢 STEEL ALLOY	
12	E型卡簧 BODY SNAP RING	合金钢 STEEL ALLOY	
13	活塞 PISTON	压铸铝合金 ALUMINUM DIECASTING	
14	活塞导向套 PISTON GUDE RING	工程塑料 ENGINEERING PLASTIC	
15	活塞密封圈 PISTON O-RING	NBR / EPDM / FKM	标配 STANDARD:NBR
16	活塞销 PISTON PIN	合金钢 STEEL ALLOY	
17	活塞销衬套 PISTON ROLLER	合金钢 STEEL ALLOY	
18	活塞导向垫片 PISTON PAD	工程塑料 ENGINEERING PLASTIC	
19	端盖 END COVER	压铸铝合金 ALUMINUM DIECASTING	蓝色静电喷涂 BLUE EPOXY COATED
20	端盖密封圈 COVER O-RING	NBR / EPDM / FKM	
21	端盖螺栓 COVER BOLT	不锈钢 STAINLSS STEEL	
22	弹簧导向套 SPRING CAP	工程塑料 ENGINEERING PLASTIC	
23	弹簧 SPRING	弹簧钢 SPRING ALLOY	表面静电喷涂 EPOXY COTED
24	限位块 STOPPER	合金钢 STEEL ALLOY	
25	调节螺栓垫片 ADJUST WASHER	不锈钢 STAINLSS STEEL	
26	锁紧螺母 ADJUST NUT	不锈钢 STAINLSS STEEL	
27	调节螺栓密封圈 ADJUST O-RING	NBR / EPDM / FKM	标配 STANDARD:NBR
28	调节螺栓 ADJUST BOLT	不锈钢 STAINLSS STEEL	

# 空气消耗量 AIR CONSUMPTION

执行机构的耗气量计算如下

双作用执行器(APD系列)	$V = (A+B)(P+1.013) \times N$
单作用执行器(APS系列)	$V = Ax(P+1.013) \times N$

V=耗气量(L)  
 A=A气室  
 B=B气室  
 P=气源压力(bar)  
 N=动作次数

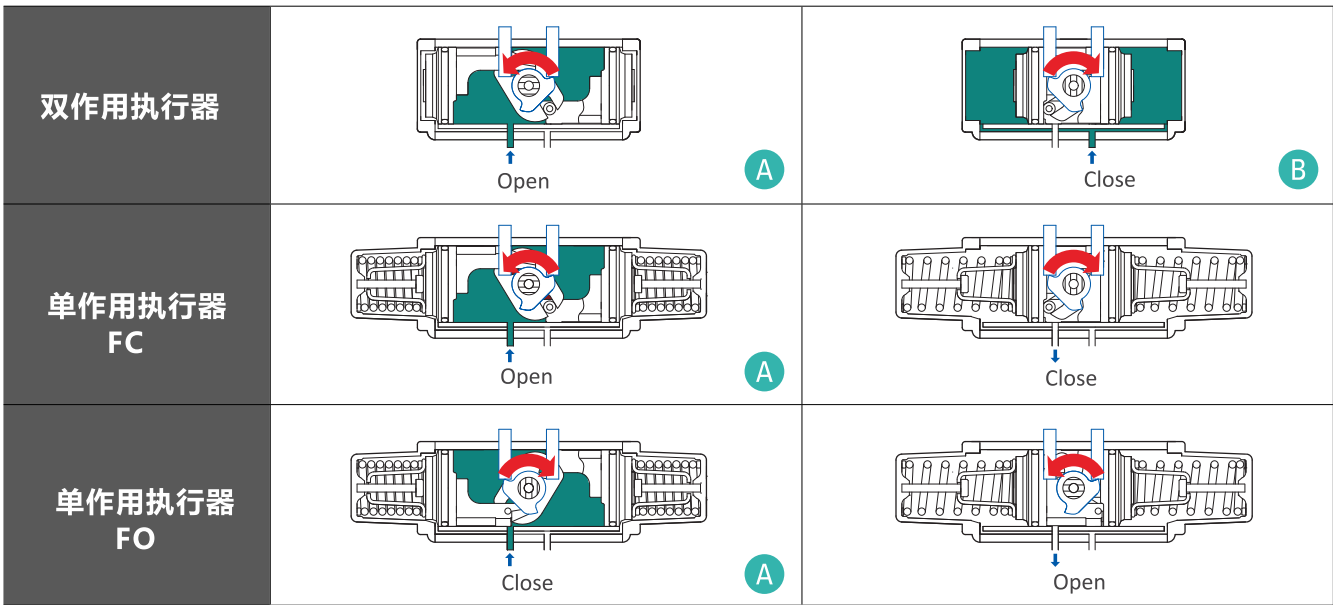

## 气缸容积 Volume

Model	双作用		Model	单作用	
	A	B		A (Fail Close)	A (Fail Open)
APD052	0.2	0.2	APS052	0.2	0.2
APD063	0.3	0.3	APS063	0.3	0.3
APD083	0.6	0.5	APS083	0.6	0.5
APD105	1.2	1.1	APS105	1.2	1.0
APD125	2.5	2.2	APS125	2.5	2.1
APD140	3.9	3.5	APS140	3.9	3.3
APD160	4.8	4.3	APS160	4.8	4.0
APD190	5.8	7.5	APS190	5.8	6.1
APD210	6.2	9.9	APS210	6.2	7.6
APD240	8.0	12.8	APS240	8.0	9.9

## 选型

### Ordering Information

动作形式 Acting type	气缸型号 Model	环境温度 Ambient temperature	弹簧类型(单作用执行器) Spring type	选项 Operating
<span style="background-color: #008080; color: white; padding: 2px;">APD</span> 双作用 Double Acting	<span style="background-color: #008080; color: white; border-radius: 50%; padding: 5px;">063</span>	<span style="background-color: #008080; color: white; border-radius: 50%; padding: 2px;">C</span> -20°C-80°C	<span style="background-color: #008080; color: white; border-radius: 50%; padding: 2px;">M</span> 标准弹簧 Middle  <span style="background-color: #008080; color: white; border-radius: 50%; padding: 2px;">P</span> 硬弹簧 Powerful	<span style="background-color: #008080; color: white; border-radius: 50%; padding: 2px;">M</span> 陶瓷化耐腐蚀处理 MTO
<span style="background-color: #008080; color: white; padding: 2px;">APS</span> 单作用 Single Acting		<span style="background-color: #008080; color: white; border-radius: 50%; padding: 2px;">L</span> -40°C-80°C		

## 双作用型 DOUBLE ACTING TYPE

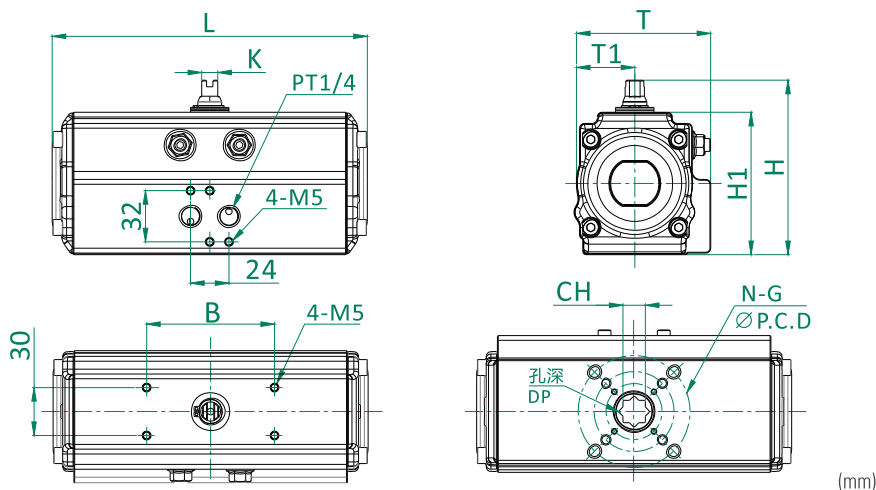

Dimension Table

MODEL	B	ISO	P.C.D	N-G	K	L	T	T1	H	H1	CH	DP	Weight (Kg)
APD052	80	F03/F05/F07	36/50/70	4-M5/M6/M8	9	162	75	40	90	70	11×11	13	1.4
APD063	80	F05/F07	50/70	4-M6/M8	13	202	89	46	107	87	14×14	17	2.3
APD083	80	F05/F07	50/70	4-M6/M8	13	253	101	49.5	126	106	17×17	19	3.9
APD105	80	F07/F10	70/102	4-M8/M10	19	311	129	61.5	148	128	22×22	26	6.7
APD125	80	F07/F10	70/102	4-M8/M10	19	390	151	71.5	174	154	22×22	26	11.3
APD140	80	F10/F12	102/125	4-M10/M12	24	431	164	77	192	172	27×27	30	16.4
APD160	80	F14	140	4-M16	24	506	188	89	216	196	36×36	30	23.7
		#F10/F12	#102/125	#4-M10/M12							#27×27		
APD190	130	F14	140	4-M16	30	578	217	102	254	224	36×36	30	34.8
APD210	130	F16	165	4-M20	36	605	231	115	284	254	46×46	60	45.5
APD240	130	F16	165	4-M20	36	755	301	152	335	305	46×46	60	65.8

# 可选项

## 扭矩 TORQUE (N.m)

型号	行程	气源压力					型号	行程	气源压力				
		4bar	4.5bar	5bar	6bar	7bar			4bar	4.5bar	5bar	6bar	7bar
APD052	0°	35.6	39.8	44.0	52.4	59.8	APD140	0°	779.0	874.0	969.0	1159.0	1339.5
	45°	22.1	25.1	27.2	32.5	37.7		45°	427.5	479.8	532.0	641.0	750.5
	90°	44.0	50.3	53.5	66.1	78.6		90°	788.5	893.0	1007.0	1263.5	1539.0
APD063	0°	65.2	73.1	79.4	93.7	108.0	APD160	0°	1187.5	1330.0	1472.5	1748.0	2033.0
	45°	41.0	46.4	51.7	61.6	71.3		45°	674.5	760.0	845.5	1011.8	1182.8
	90°	83.0	94.5	104.4	125.8	147.2		90°	1363.3	1581.8	1805.0	2123.3	2503.3
APD083	0°	135.9	155.3	170.0	203.9	233.0	APD190	0°	1877.2	2123.6	2346.5	2780.6	3191.2
	45°	77.7	87.4	97.1	116.5	140.8		45°	1349.2	1513.5	1666.0	1994.5	2334.8
	90°	170.0	194.2	223.3	271.9	325.3		90°	2370.0	2686.7	3015.3	3730.9	4423.2
APD105	0°	289.0	322.3	355.7	428.0	489.1	APD210	0°	2612.5	2888.0	3163.5	3676.5	4218.0
	45°	172.3	194.6	216.8	261.3	311.2		45°	1491.5	1662.5	1852.5	2223.0	2593.5
	90°	311.2	355.7	400.1	489.1	578.0		90°	2432.0	2755.0	3068.5	3705.0	4322.5
APD125	0°	508.3	574.8	631.8	745.8	855.0	APD240	0°	4275.0	4750.0	5272.5	6222.5	7125.0
	45°	323.0	361.0	399.0	475.0	555.8		45°	2498.5	2812.0	3097.0	3743.0	4389.0
	90°	612.8	698.3	821.8	983.3	1144.8		90°	4617.0	5177.50	5776.0	6944.5	8189.0



单作用型  
SINGLE ACTING TYPE

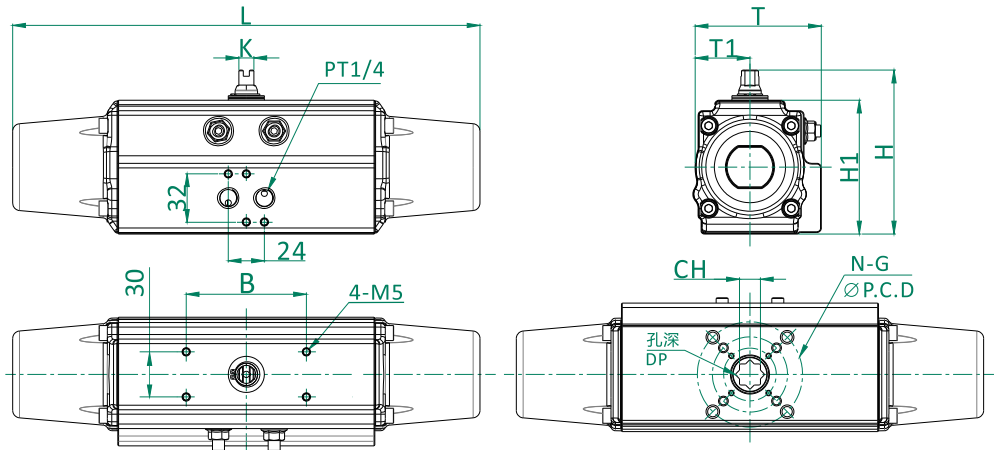

Dimension Table

MODEL	B	ISO	P.C.D	N-G	K	L	T	T1	H	H1	CH	DP	Weight (Kg)
APS052	80	F03/F05/F07	36/50/70	4-M5/M6/M8	9	257	75	40	90	70	11×11	13	1.6
APS063	80	F05/F07	50/70	4-M6/M8	13	314	89	46	107	87	14×14	17	3.0
APS083	80	F05/F07	50/70	4-M6/M8	13	421	101	49.5	126	106	17×17	19	5.3
APS105	80	F07/F10	70/102	4-M8/M10	19	500	129	61.5	148	128	22×22	26	9.5
APS125	80	F07/F10	70/102	4-M8/M10	19	606	151	71.5	174	154	22×22	26	17.6
APS140	80	F10/F12	102/125	4-M10/M12	24	682	164	77	192	172	27×27	30	23.9
APS160	80	F14	140	4-M16	24	781	188	89	216	196	36×36	30	36.6
		#F10/F12	#102/125	#4-M10/M12							#27×27		
APS190	130	F14	140	4-M16	30	894	217	102	254	224	36×36	30	56.9
APS210	130	F16	165	4-M20	36	982	231	115	284	254	46×46	60	77.2
APS240	130	F16	165	4-M20	36	1108	301	152	335	305	46×46	60	119.6

# 可选项

扭矩  
TORQUE (N.m)

型号	行程	标准弹簧				硬弹簧		型号	行程	标准弹簧				硬弹簧	
		弹簧	4bar 气源压力	4.5bar 气源压力	5bar 气源压力	弹簧	6bar 气源压力			弹簧	4bar 气源压力	4.5bar 气源压力	5bar 气源压力	弹簧	6bar 气源压力
APS052	0°	16.2	19.0	22.8	26.6	23.0	28.3	APS140	0°	384.8	460.8	555.8	655.5	547.8	693.5
	45°	12.0	8.2	10.8	13.6	16.5	14.3		45°	228.0	199.5	247.0	313.5	332.5	318.3
	90°	24.2	6.2	11.4	16.2	33.3	14.0		90°	446.5	275.5	375.3	475.0	617.5	465.5
APS063	0°	43.7	41.3	49.4	58.0	56.6	64.9	APS160	0°	503.5	750.5	902.5	1045.0	888.3	1059.3
	45°	24.9	17.6	23.3	28.5	34.4	32.3		45°	289.8	380.0	465.5	551.0	498.8	508.3
	90°	47.2	20.0	30.6	41.2	65.2	39.9		90°	536.8	608.0	769.5	950.0	940.5	731.5
APS083	0°	76.0	76.0	95.0	114.0	114.0	123.5	APS190	0°	1035.5	921.5	1111.5	1292.0	1548.5	1292.0
	45°	42.8	33.3	42.8	57.0	61.8	61.8		45°	579.5	465.5	598.5	741.0	874.0	703.0
	90°	85.5	42.8	61.8	85.5	118.8	85.5		90°	1140.0	608.0	855.0	1092.5	1681.5	931.0
APS105	0°	114.0	133.0	166.3	195.5	152.0	237.5	APS210	0°	1206.5	1491.5	1833.5	2109.0	1681.5	2375.0
	45°	76.0	57.0	76.0	95.0	99.8	118.8		45°	674.5	717.3	921.5	1097.3	1035.5	1092.5
	90°	152.0	61.8	99.8	133.0	209.0	152.0		90°	1239.8	978.5	1349.0	1719.5	1947.5	1472.5
APS125	0°	285.0	318.3	384.8	451.3	408.5	470.3	APS240	0°	2213.5	2555.5	3097.0	3610.0	3277.5	3942.5
	45°	166.3	161.5	204.3	247.0	237.5	247.0		45°	1254.0	1282.5	1605.5	1947.5	1738.5	2071.0
	90°	318.3	237.5	318.3	408.5	446.5	384.8		90°	2432.0	1767.0	2318.0	2945.0	3315.5	2888.0

# AKCESERVIS

埃克(山东)流体控制设备有限公司  
SHANDONG AKCESERVIS FLOW-CONTROLS CO., LTD

地址:山东省济南市二环东路1966号A座1401  
TEL:+86-0531-88903632 88905632  
FAX:+86-0531-88905582  
E-mail: sales@akceservis.com

[www.akceservis.com](http://www.akceservis.com)